

MSB1S8AA

乾式單板電磁式煞車器-自動調整型 Dry Single-Plate Magnetic Brake Self-Adjustment

產品規格表 SPECIFICATIONS:

型號 Model	靜摩擦轉距 Static Torque kgm(Nm)	電流 Current	電壓 Voltage	消耗功率 Power at 75°C	慣性矩(煞車板側) GD ² (Plate)	重量 (kg) Weight
MSB1S8AA	1.8 kgm	1.0A	24VDC	16.3W	$5.2 \times 10^{-3} \text{ kgfm}^2$	2.2

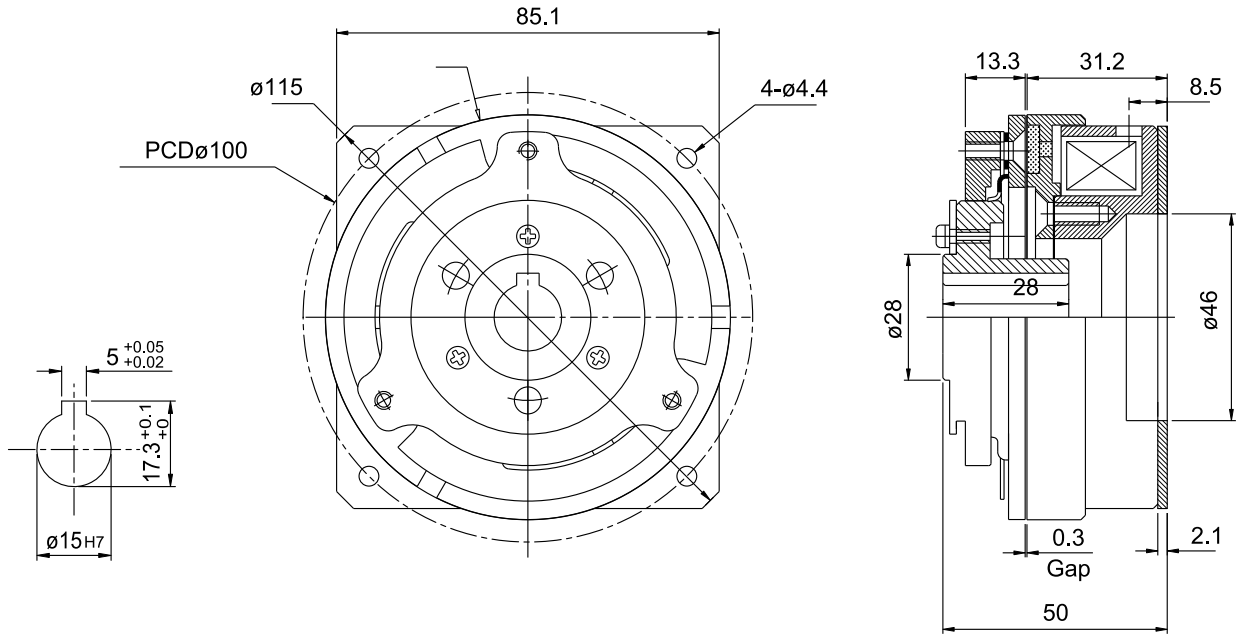

MSC1S8AA

乾式單板電磁式離合器-自動調整型 Dry Single-Plate Magnetic Clutch Self-Adjustment

產品規格表 SPECIFICATIONS:

型號 Model	靜摩擦轉距 Static Torque kgm(Nm)	電流 Current	電壓 Voltage	消耗功率 Power at 75°C	慣性矩(電樞側) GD ² (Armature)	慣性矩(電樞板側) GD ² (Plate)	重量 (kg) Weight
MSC1S8AA	1.8 kgm	1.0A	24VDC	24W	$3.4 \times 10^{-3} \text{ kgfm}^2$	$5.5 \times 10^{-3} \text{ kgfm}^2$	2.3

