

# MG1 Series

微小型電磁煞車器 Micro Magnetic Brake 附導座 with plating hub

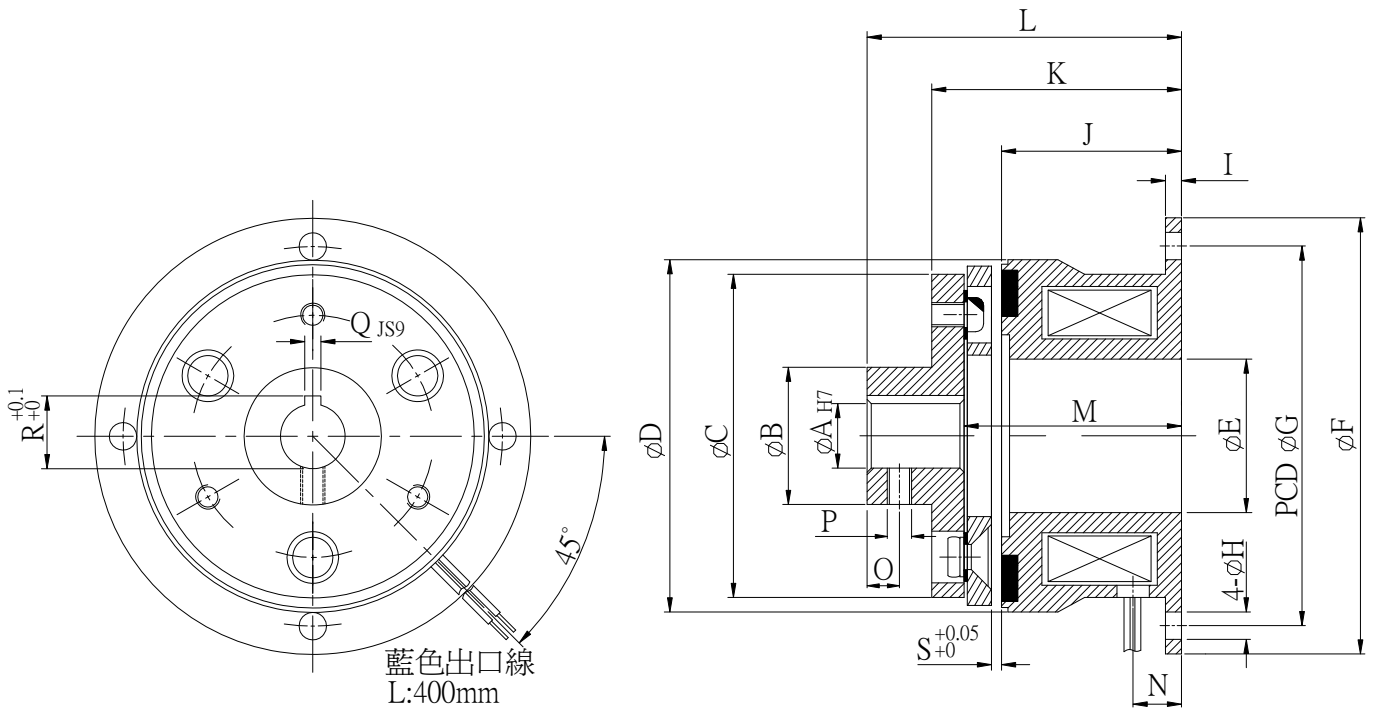

型號 MODEL		MG1S06AA	MG1S09AA	MG10S2AA	MG10S4AA
靜摩擦轉距 (Nm)		0.6	0.9	2.2	4.5
功率 [24V](W) at 20°C		6.2	6	8	10
徑向尺寸	A	6	6	8	10
	B	12.9	15	17	24
	C	28	32	40	50
	D	31	34	43.6	54.5
	E	11	13	19	26
	F	39	45	54	65
	G	33.5	38	47	58
	H	3.4	3.4	3.4	3.4
軸向尺寸	I	1.5	2	2	2
	J	16	18.9	22.3	23.5
	K	21.3	24.4	28.4	29.7
	L	26.3	31.4	37.4	38.7
	M	18.3	21.4	25.4	26.7
	N	4	5	6	6
	O	2.5	4	4	5
	P	M3*P0.5	M3*P0.5	M3*P0.5	M3*P0.5
	Q	2	2	2	3
	R	7	7	9	11.4
	S	0.1	0.1	0.15	0.2